

LEADER 400C

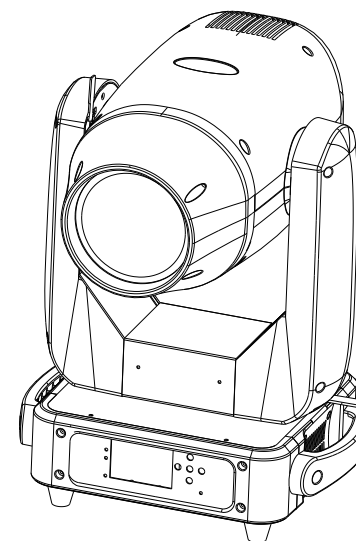

CE   IP20 t_a 40°C t_c 150°C

User Manual

KEEP THIS MANUAL FOR FUTURE NEEDS

1 SAFETY INSTRUCTIONS



CAUTION

Becareful with your operations. With a dangerous voltage you can suffer a dangerous electric shock when touching wires!

This device has left the factory in perfect condition. In order to maintain this condition and to ensure a safe operation, it is absolutely necessary for the user to follow the safety instructions and warning notes written in this user manual.



IMPORTANT

Damages caused by the disregard of this user manual are not subject to warranty. The dealer will not accept liability for any resulting defects or problems.

If the device has been exposed to temperature changes due to environmental changes, do not switch it on immediately. The arising condensation could damage the device. Leave the device switched off until it has reached room temperature.

This device falls under protection-class I. Therefore it is essential that the device be earthed.

The electric connection must carry out by qualified person.

The device shall only be used with rate voltage and frequency.

Make sure that the available voltage is not higher than stated at the end of this manual.

Make sure the power cord is never crimped or damaged by sharp edges. If this would be the case, replacement of the cable must be done by an authorized dealer.

Always disconnect from the mains, when the device is not in use or before cleaning it. Only handle the power cord by the plug. Never pull out the plug by tugging the power cord.

During initial start-up some smoke or smell may arise. This is a normal process and does not necessarily mean that the device is defective, it should decrease gradually.

Please don't project the beam onto combustible substances.

Fixtures cannot be installed on combustible substances, keep more than 50cm distance with wall for smooth air flow, so there should be no shelter for fans and ventilation for heat radiation.

If the external flexible cable or cord of this luminaire is damaged, it shall be exclusively replaced by the manufacturer or his service agent or a similar qualified person in order to avoid a hazard.

7 MAINTENANCE AND CLEANING

The following points have to be considered during the inspection:

- 1) All screws for installing the devices or parts of the device have to be tightly connected and must not be corroded.
- 2) There must not be any deformations on the housing, color lenses, fixations and installation spots (ceiling, suspension, trussing).
- 3) Mechanically moved parts must not show any traces of wearing and must not rotate with unbalances.
- 4) The electric power supply cables must not show any damage, material fatigue or sediments.

Further instructions depending on the installation spot and usage have to be adhered by a skilled installer and any safety problems have to be removed.



CAUTION

Disconnect from mains before starting maintenance operation.



In order to make the lights in good condition and extend the life time, we suggest a regular cleaning to the lights.

- 1) Clean the inside and outside lens each week to avoid the weakness of the lights due to accumulation of dust.
- 2) Clean the fan each week.
- 3) A detailed electric check by approved electrical engineer each three month, make sure that the circuit contacts are in good condition, prevent the poor contact of circuit from overheating.

We recommend a frequent cleaning of the device. Please use a moist, lint- free cloth. Never use alcohol or solvents.

There are no serviceable parts inside the device. Please refer to the instructions under "Installation instructions".

Should you need any spare parts, please order genuine parts from your local dealer.

CH16	Rotating pattern	130-139	Dither pattern from slow to fast 6
		140-149	Dither pattern from slow to fast 7
		150-200	Forward flow from fast to slow
		201-205	Stop
		206-255	Reverse flow from slow to fast
CH17	Pattern rotation	0-127	0-400 degrees
		128-190	Forward flow from fast to slow
		191-192	Stop
		193-255	Reverse flow from slow to fast
CH18	Prism 1	0-127	Remove the prism
		128-255	Insert Prism 1
CH19	Prism 1 rotation	0-127	0-400 degrees
		128-187	Forward flow from fast to slow
		188-195	Stop
		196-255	Reverse flow from slow to fast
CH20	Prism 2	0-127	Remove the prism
		128-255	Insert Prism 2
CH21	Prism 2 rotation	0-127	0-400 degrees
		128-187	Forward flow from fast to slow
		188-195	Stop
		196-255	Reverse flow from slow to fast
CH22	Atomization	0-127	None
		128-255	Atomization
CH23	Reset	210-215	Reset XY for more than 6 seconds
		220-235	Motor with reset effect over 6 seconds
		240-255	Reset all over 6 seconds

2 UNPACKING

The LEADER 400 is a new generation professional and intelligent LED moving head spot designed with a full CMY color mixing system plus CTO color correction, smooth and linear zoom from 4°-35°. The SPOT features a new high intensity and efficiency cool white 400W LED engine (8500K) delivering ultra high light output through a set of high resolution and precise optics that helps to provide extremely clear and even spot coverage. It offers a full complement of other professional characteristics, a rotating gobo wheel with 7 rotating and interchangeable glass gobos, a static gobo wheel with 12 gobos, a color wheel with 8 dichroic colors, 2 rotating prisms, frost filter, linear electronic focus, linear dimmer, variable speed shutter/strobe, full color 180° reversible TFT display with 5 control buttons, etc. The LEADER 400 supports DMX, RDM (Remote Device Management).

The fixture's exterior housing is beautifully balanced design with supremely harmonious interior structure for remarkable control. The sculpted body of the LEADER 400 achieves more than just a striking look.

It's fast and quiet operation LED moving head spot. The fixture is tuned with proper LED refresh rate for flicker free operation for TV and FILM. It's a perfect option for large scale live concerts, TV productions, road shows, theatre, etc.

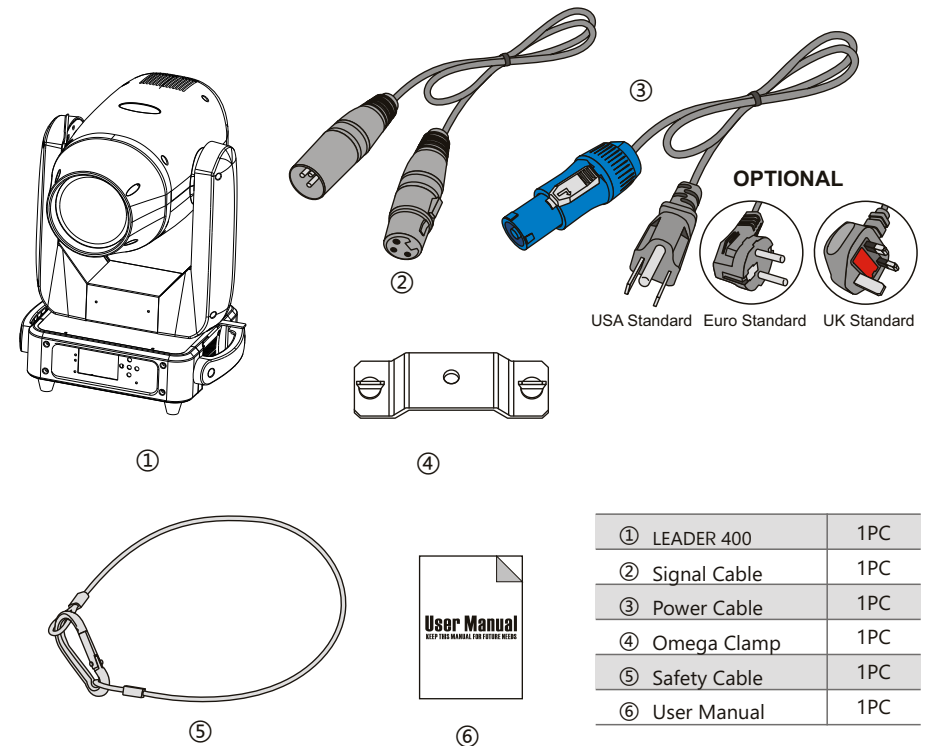

3 FEATURES & SPECIFICATIONS

Features

400W White LED engine
 Color Temperature: 8500K (customizable)
 CRI: ≥85 (customizable)
 Flicker free operation for broadcast TV and FILM
 Life Span: 20000H
 A set of high resolution and precise optics
 4°-35°Smooth and quiet linear motorized zoom
 Smooth and precise linear focus
 Fine control for focus
 PAN movement: 540°(8/16 bit)
 PAN movement: 270°(8/16 bit)
 Fast, quiet, smooth and precise 3-Phase motors
 Smooth, fast and precise resolution for PAN/TILT movement with low noise operation
 Scan position memory, auto reposition after unexpected movement
 PAN/TILT reversible
 Full CMY color mixing system with linear CTO color correction
 1 Color wheel with 8 dichroic colors plus open (half color mode available)
 Variable direction rainbow effect with speed adjustable
 1 Rotating gobo wheel with 7 rotatable and interchangeable glass gobos plus open with speed adjustable, stream effect, dithering effect and rotatable clockwise or anticlockwise
 Gobo size 22.7mm (external)/14mm (inner)
 Fine control for rotating gobo wheel
 1 Static gobo wheel with 12 gobos plus open
 Gobo overlay (gobo morphing)
 3-Facet prism with variable speed and direction
 8-Facet prism with variable speed and direction
 0-25Hz LED shutter/strobe effect with variable speed
 Preset variable/random strobe and dimming pulse effect
 0-100% Smooth linear LED dimming
 23 DMX channels USITT DMX-512
 DMX512, master-slave, or auto operation
 DMX recorder and edit function integrated
 RDM available (Remote Device Management)
 Shielded input signal protection for stable signal without interference
 3-Pin XLR DMX connectors IN/OUT
 Electronic supply with active PFC
 AC100-240V 50/60Hz
 PowerCON IN/ OUT with power switch and fuse
 430W Power consumption
 -25°C to 45°C ambient temperature
 IP20 protection rating
 N.W.: 22.5kg
 G.W.: 25.5kg
 Product Dimensions: 270(D)*381(W)*650(H)mm
 Packing Dimensions: 520(D)*630(W)*500(H)mm

CH11	CMY2	0-255	Linear CMY red
CH12	CMY3	0-255	Linear CMY yellow
CH13	Pattern	0-9	White light
		10-14	Pattern 1
		15-19	Pattern 2
		20-24	Pattern 3
		25-29	Pattern 4
		30-34	Pattern 5
		35-39	Pattern 6
		40-44	Pattern 7
		45-49	Pattern 8
		50-54	Pattern 9
		55-59	Pattern 10
		60-64	Pattern 11
		65-69	Dither Pattern 1 from Slow to Fast
		70-74	Slow to Fast Jitter Pattern 2
		75-79	Dither pattern from slow to fast 3
		80-84	Dither pattern from slow to fast 4
		85-89	Dither pattern from slow to fast 5
		90-94	Dither pattern from slow to fast 6
		95-99	Dither pattern from slow to fast 7
		100-104	Dither pattern from slow to fast 8
105-109	Dither pattern from slow to fast 9		
110-114	Dither pattern 10 from slow to fast		
115-119	Dither pattern 11 from slow to fast		
120-127	Great circle		
128-190	Forward flow from fast to slow		
191-192	Stop		
193-255	Reverse flow from slow to fast		
CH14	Zoom in	0-255	From small to large
CH15	Focus	0-255	From far to near
CH16	Rotating pattern	0-9	White light
		10-19	Pattern 1
		20-29	Pattern 2
		30-39	Pattern 3
		40-49	Pattern 4
		50-59	Pattern 5
		60-69	Pattern 6
		70-79	Pattern 7
		80-89	Dither Pattern 1 from Slow to Fast
		90-99	Slow to Fast Jitter Pattern 2
		100-109	Dither pattern from slow to fast 3
		110-119	Dither pattern from slow to fast 4
		120-129	Dither pattern from slow to fast 5

6 DMX CHANNELS

Channel 1	Function	value	Description
CH1	X-axis	0-255	0-540 degrees
CH2	X-axis fine tuning	0-255	0-2 degrees
CH3	Y axis	0-255	0-270 degrees
CH4	Y-axis fine tuning	0-255	0-1 degrees
CH5	XY Speed	0-255	From fast to slow
CH6	Dimming	0-255	0-100% dimming
CH7	Stroboscopic	0-3	Turn off the light
		4-103	Pulse strobe from slow to fast
		104-107	Turn on light
		108-155	Gradual frequency conversion flash from slow to fast (gradual opening)
		156-207	Frequency conversion flash from slow to fast (gradual off)
		208-212	Turn on light
		213-251	Random strobe from slow to fast
		252-255	Turn on light
CH8	Color	0-9	White light
		10-19	Color 1
		20-29	Color 2
		30-39	Color 3
		40-49	Color 4
		50-59	Color 5
		60-69	Color 6
		70-79	Color 7
		80-89	Color 8
		90-99	White Light + Color 1
		100-109	Color 1 + Color 2
		110-119	Color 2 + Color 3
		120-129	Color 3 + Color 4
		130-139	Color 4 + Color 5
		140-149	Color 5 + Color 6
		150-159	Color 6 + Color 7
		160-169	Color 7 + Color 8
		170-179	Color 8 + White Light
		180-215	Forward flow from fast to slow
		216-220	Stop
221-255	Reverse flow from slow to fast		
CH9	CTO	0-255	Linear CTO
CH10	CMY1	0-255	Linear CMY blue

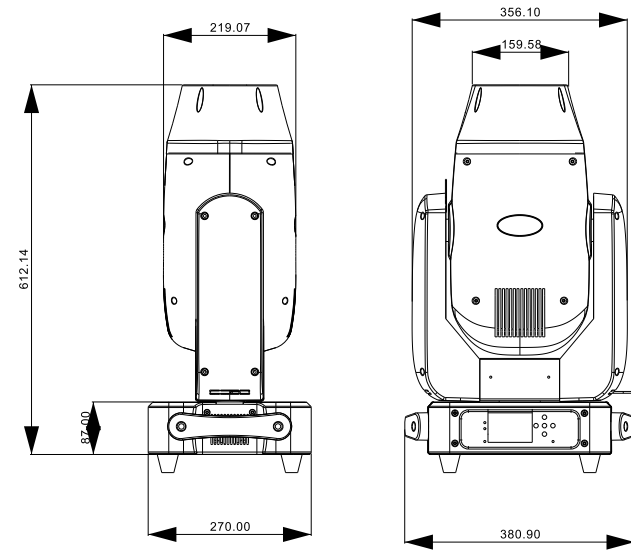

Static Gobo

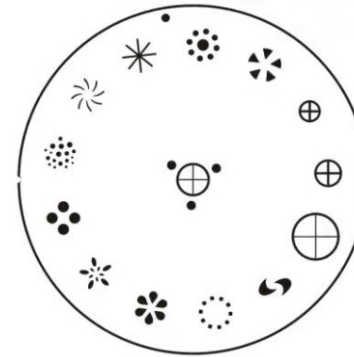

Colors

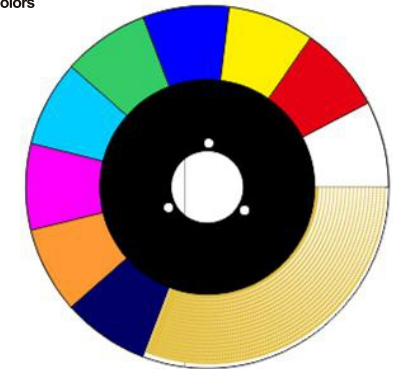

ROTATING GOBOS(OutDia22.7MM*InDia14MM)



CMY FILTER

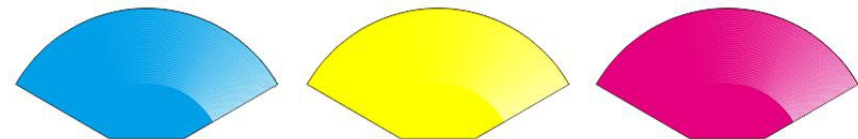

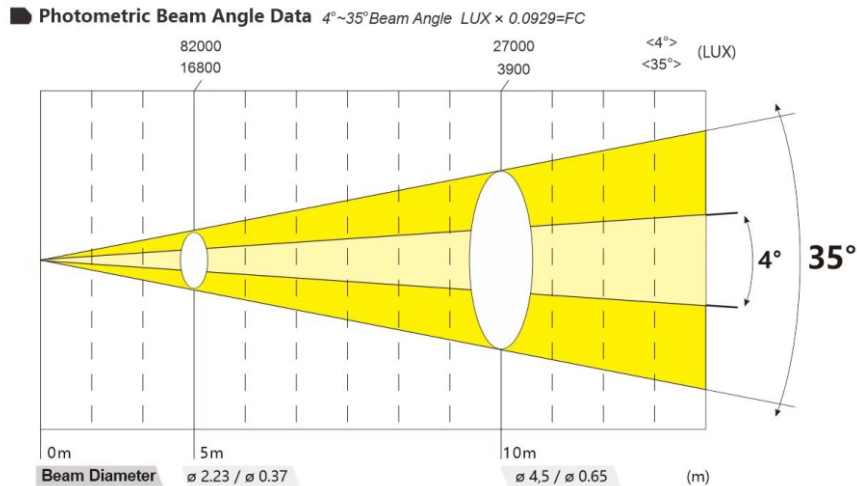

4 OPERATION INSTRUCTIONS

- The LEADER 400 is for beam effect for on-site decoration purpose.
- Don't turn on the fixture if it's been through severe temperature difference like after transportation because it might damage the light due to the environment changes. So make sure to operate the fixture until it is in normal temperature.
- This light should be keep away from strong shaking during any transportation or movement.
- Don't pull up the light by only the head, or it might cause damages to the mechanical parts.
- Don't expose the fixture in overheat, moisture or environment with too much dust when installing it. And don't lay any power cables on the floor. Or it might cause electronic shock to the people.
- Make sure the installation place is in good safety condition before installing the fixture.
- Make sure to put the safety chain and check whether the screws are screwed properly when installing the fixture.
- Make sure the lens are in good condition. It's recommended to replace the units if there are any damages or severe scratch.
- Make sure the fixture is operated by qualified personnel who knows the fixture before using.
- Keep the original packages if any second shipment is needed.
- Don't try to change the fixtures without any instruction by the manufacturer or the appointed repairing agencies.
- It is not in warranty range if there are any malfunctions from not following the user manual to operate or any illegal operation, like shock short circuit, electronic shock, lamp broke, etc.

- ♦ **P/T Rectify:** Disable or enable position rectify function.
 - OFF--> Disable P/T rectify
 - ON--> Enable P/T rectify-(Default)
- ♦ **Pan Offset:** Set PAN original position. **Default: 10**
- ♦ **Tilt Offset:** Set TILT original position. **Default: 10**
- ♦ **Lamp when:**
 - PowerON--> Turn on the lamp when power on.(Default)
 - RstDone--> Turn on the lamp after reset.
 - Manual--> Manually turn on the lamp.
- ♦ **Data hold:**
 - OFF--> When no DMX signal,return to middle position.(Default)
 - ON--> When no DMX signal,stop in the final position.
- ♦ **Factory Setting:** Restore all parameter to factory setting.

2.3.6 STAT-->Status: View status

Enter the page as shown in Figure 12:

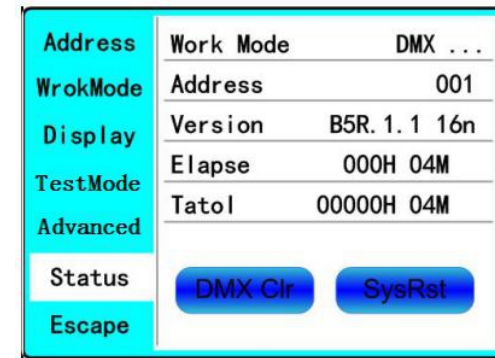

Figure 12 page of status

- ♦ **Work Mode:** Show the current working mode.
- ♦ **Address:** Show the current address.
- ♦ **Version:** Show the version of the lamp.
- ♦ **Elapse:** Working hours after turn on.
- ♦ **Tatol:** Cumulative hours of operation

ON--> Enable touch function.(Default)

OFF--> Dosable touch function.

- **Touch adjust:** Adjust touch function. Normally, not enter this item.

2.3.4 TEST--> TestMode

Enter the page as shown in Figure 10, Light will into test mode, in this mode, the light does not receive the data for DMX controller:

Address	PAN	000
WorkMode	TILT	000
Display	FOCUS	000
TestMode	COLOR	000
	GOBO	000
Advanced	PRISM	000
Status	FROST	000
Escape	STROBE	000

Figure 10 page of Test

- **PAN:** range for 0 to 255;
- **TILT:** range for 0 to 255;
- **FOCUS:** range for 0 to 255;
- **COLOR:** range for 0 to 255;
- **GOBO:** range for 0 to 255;
- **PRISM:** range for 0 to 255;
- **FROST:** range for 0 to 255;;
- **STROBE:** range for 0 to 255;

2.3.5 ADVA-->Advanced: Set light run parameter

Enter the page as shown in Figure 10, set the parameter of light:

Address	PAN Inset	OFF
WorkMode	TILT Inset	OFF
Display	P/T Rectify	ON
TestMode	PAN Offset	010
	TILT Offset	010
Advanced	Lamp when	Power ON
Status	Data hold	OFF
Escape	Factory Setting	

Figure 11 page of run parameter

- **Pan Invert: Reverse PAN move**
OFF--> Pan Normal move.(Default)
ON--> Reverse PAN move.
- **Tilt Invert: Reverse TILT move**
OFF--> Tilt Normal move.(Default)
ON--> Reverse Tilt move.

5 MENU OPERATIONS

2.2.2 Parameter value setting

When the selected item is value need to been modified, the dialog shown in Figure 4 will popup.

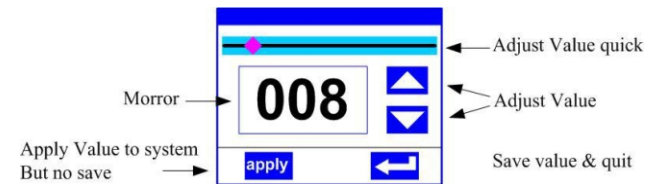

Figure 4 Dialog of value setting

- **Modify value:** Can quickly modify value via pull the slider to the desired position, or click the button of ' up' or ' down' whit finger on the right side to set the exact desired value, another way is roll encoder on the right hand side of panel.
- **Apply value:** When Value had been modified, Then press the bottom of ' apply' in the left corner to apply to the light, but hav' t saved;
- **Save Value:** Any time, click on the lower right corner of the "OK" button, the setting will been saved into internal memory.

2.2.3 Boolean parameter setting

- when the selected parameters is a Boolean value (such as ON or OFF), can directly modify setting by chik corresponding item, the setting will been saved right now.
- When the parameter is a key item, chik corresponding item, a dialog shown in Figure 5 will been popup ask for the confirm. Chik ' sure' to confirm.

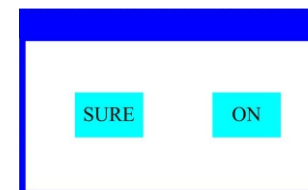

Figure 5 Dialog of confirm

2.2.4 Sub Menu (Parameter)

Chick item of main menu, enter corresponding sub menu, shown in Figure 6, total 6 sub menu, includes class of parameter and status:

- **ADDRESS:** Set light DMX address.
- **WORKMOD:** Set light work mode, master or slave mode when in auto run mode.
- **DISPLAY:** Set display parameter, eg. select language.
- **TEST:** Used for test light, modify DMX channel data to test function, the corresponding function of reference channel function table.
- **ADVANCE:** Set light running parameter.
- **STATUS:** view light current status.

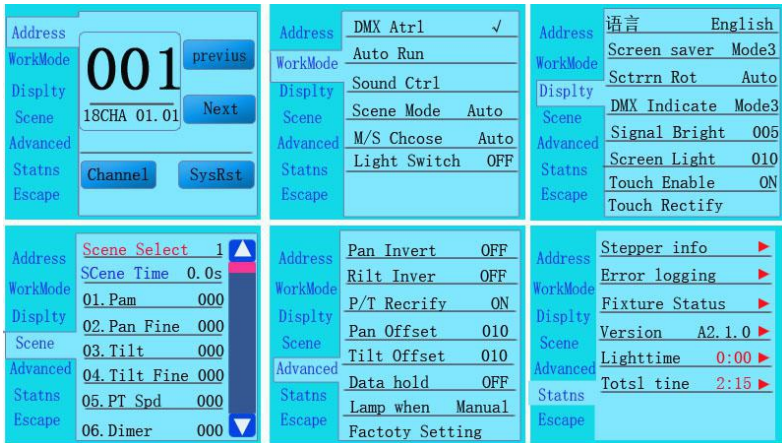

Figure 6 Parameter menu

Operation and parameter instruction

Via following operation, enter sub menu(parameter menu) shown in Figure 6

- In main menu, click 1/6 function button into corresponding parameter menu.
- In sub menu(page), click main item on the left side of displayer, can shift to corresponding sub menu(page) quickly.

2.3.1 ADDR--> Address: Set DMX Address

Click and select the "ADDR", can enter the page of DMX address setting, range from 1 to 512, the address code shouldn't be not greater than (512- channels quantity), otherwise the light will not be controlled. Following is the operation:

Enter the page of DMX address, as shown in Figure 7, click the blank area in right side of display will pop-up diglog as in Fig. 4, modify value, then click ' ENTER' to confirm and save DMX address code.

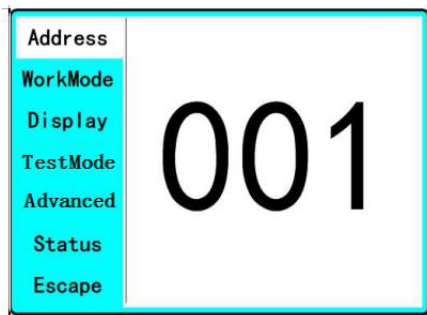

Figure 7 page of DMX Address

2.3.2 MODE--> WorkMode: Set Light work mode

Enter the page of ' WorkMode' as shown in Figure 8 and modify setting. Can set light work mode, control lamp and DMX channel mode.

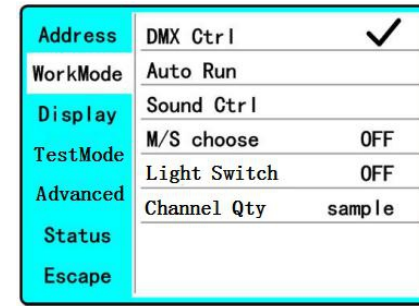

Figure 8 page of work mode

- ♦ **DMX Ctrl:** Choose to set DMX Mode,
- ♦ **Auto Run:** Choose to set Auto Mode,
- ♦ **Sound Ctrl:** Choose to set Sound Mode,
- ♦ **M/S Choose:** Available just in ' AUTO RUN' or ' SOUND Ctrl' mode.
ON--> Master. (Data will be send to other slave lamp immediately.)
OFF--> Slaver.(NOT send data to other lamp via DMX Cable).(Default)
- ♦ **Light Switch:**
ON--> Turn on the light,
OFF--> Turn off the light.
- ♦ **Channel Qty:** Light support 2 DMX Channel mode: sample or extend,
Simple --> 16CH.(Default)
Expand--> 20CH(or null).

DISP-->DISPLAY: Set display

Light support 2 language, rotation display, Enter page as shown in Figure9 to set parameter following:

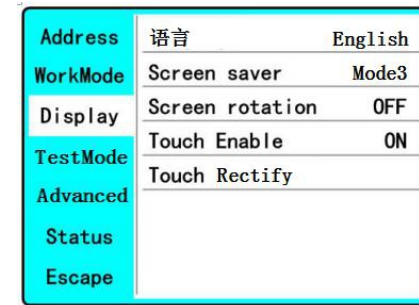

Figure9 page of display

- ♦ **Language:** English / 中文.
- ♦ **Screen Saver:** when panel is idle(these is no operation in 10 second), displayer will enter saver status.
OFF--> No screen saver.
Mode1--> Power-saving mode, turn off the display.
Mode2--> Displays the current address.
Mode3--> Displays the icon and the current working mode.(Default)
- ♦ **Screen Rotion: To turning display.**
ON--> Normal display.(Default)
OFF--> 180° turning display.
- ♦ **Touch enable:** Disable or enable touch function,.